

INFINITY²⁶

Quick Reference Card

Needle and Thread Information

Use the correct needle system (134). Choose from sizes 12 through 21, according to the type of thread used. A guide to help you choose the correct combination of needle and threads is always available on the HQ Infinity. From the Home screen, tap the **System Information** button and choose the **Needle and Thread Guide** button.

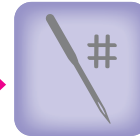

To Thread the HQ Infinity

1. Place thread cone onto spool post (1) on the thread tray, insert the thread through the thread-mast eyelet (2) from back to front, continuing to the thread guide (3).
2. Continue to the three-hole thread guide (4). Wrap all three holes from back to front, being careful not to cross threads. This is recommended for most threads. However, some very delicate threads or metallic threads may require less tension. If you are having problems with thread breaking, try threading only one or two holes of the three-hole thread guide.
3. The thread continues down to the tension assembly (5) **IMPORTANT:** The thread must be flossed up between the two tension discs. If the thread is not firmly in place between the two tension discs, the thread will lay on top of the tension discs (no tension) and thread looping on the bottom of the quilt can occur.
4. After the thread is in place, be sure that the thread catches on the take-up spring. Then guide the thread under the tension thread guide (6) and under the stirrup thread guide (7).
5. Bring the thread up and through the hole of the take-up lever (8) from back to front, and then through the pigtail thread guide (9), and thread through the needle bar thread guide hole (10).
6. Make sure the thread follows the groove down the front of the needle (11) and insert the thread through the eye of the needle from front to back. While pulling thread through the eye of the needle be careful that the thread does not twist around the needle.

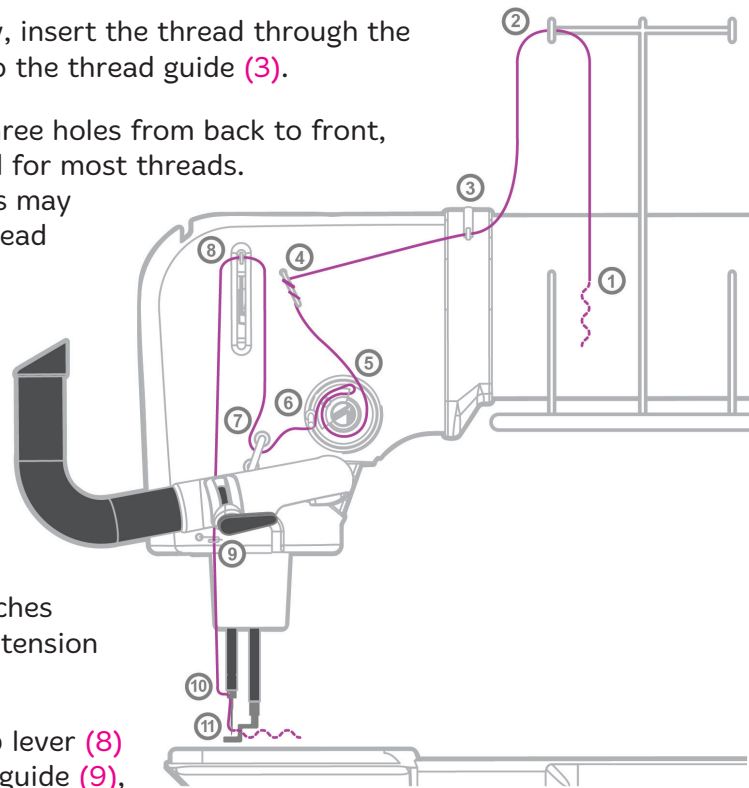

Customize Handlebar Buttons

Select the **Settings** button, then select the **Handlebar** button.*

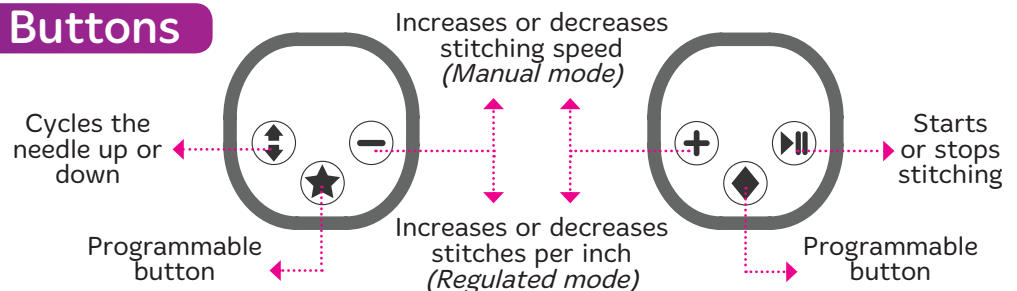

*Left/Right Swap should be determined before applying button membranes during setup.

HQ Infinity Screen Buttons

Stitching Modes

Green = selected

Manual Stitching Mode: Touch the Manual button and then specify the stitches per minute (SPM) by pressing the (+) or (-) button or selecting one of the three SPM presets. The faster you move the machine, the longer the stitches become.





Regulated Stitching Mode: Touch the Regulated button and then select either Cruise or Precision stitch regulation. A consistent stitch length (stitches per inch) will be maintained regardless of how fast the machine is moved, unless moved too fast for the machine to keep up.

Cruise Stitch Regulation: Touch the Cruise button and specify the stitches per inch (SPI) and stitches per minute (SPM) cruise settings. Machine starts to stitch immediately, at the chosen SPM cruise speed, when the Start/Stop button on the handlebars is pressed. When you begin to move the machine, a consistent stitch length will be maintained (SPI). Press Start/Stop again to stop stitching.

Precision Stitch Regulation: In this mode, the machine stitches only when the machine is moved. Touch the Precision button and specify the stitches per inch (SPI). Press the Start/Stop button on the handlebars and move the machine to start quilting. When you stop moving the machine, the needle will pause in mid-stroke. Move the machine to resume stitching.

△ **CAUTION:** While in Precision mode, stitching can happen accidentally if the machine is bumped. To prevent inadvertent stitches, press the Start/Stop button on the handlebars when not actively quilting. The needle will return to the currently selected Up/Down position.

Toolbar Buttons

 Home Touch to return to home screen.	 Start/Stop Indicator Shows the current chosen setting of the handlebar Start/Stop button.	 Video Camera Touch to view the video camera.
 Lights	 Machine Tools	 Machine Settings
 System Information (includes threading guide and needle/thread guide)		

Main Screen Buttons

 **Tie-off:** Perform a tie-off at the start or finish of a line of stitching by touching the button and gently moving the machine to perform the preset number of stitches. Number can be changed in the settings menu.

 **Needle-stop:** Touch to toggle between having the needle stop in the up or down position when you stop stitching. It does not affect the needle at the time you touch the button. Your choice displays in green.

 **Easy-Set Tension®:** The number on the button indicates the current tension, which is set by manually turning the tension knob.

 **Reset-bobbin:** If you are using the low-bobbin alarm, press this button after a bobbin change to reset the reading to indicate that you have inserted a full bobbin. The number that appears on the button shows an estimate of how much thread remains on the bobbin. The closer to zero, the less thread remains on the bobbin.





 **NOTE:** Number does not indicate yards. See *To add new bobbin configuration and record bobbin capacity* in the Toolbar Options section of the online user manual.

 **On-screen hand wheel:** Rotate the back hand wheel and cycle the needle and hopping foot from the screen by dragging your finger down the icon in the direction of the arrows.

△ **CAUTION:** Do not drag in the opposite direction.







Machine Tools

 These buttons are available after selecting the Machine Tools button.

 <i>Timer, counter, and alarm</i>	 <i>Calculator</i>	 <i>Software updater</i>	 <i>Tension assembly reset</i>	 <i>Diagnostics</i>
---	--	--	--	---

Machine Settings

 These buttons are available after selecting the Machine Settings button.

 <i>Customizes top tension presets</i>	 <i>Low-bobbin alarms</i>	 <i>Customize handlebar buttons</i>	 <i>Pinpoint needle laser on/off</i>	 <i>Alarms on/off</i>	 <i>Tie-offs</i>	 <i>Languages</i>
--	---	--	--	---	--	---