

SPRING BLING

Spring Bling

62" x 62"

Featuring "Spring Symphony" from RJR Fabrics

| | |
|---------------------------------|-------------|
| Cream Solid #9617-67 | 3 1/4 yards |
| Turquoise Solid #9617-292 | 3/4 yard |
| Blue Butterfly Print #1816-01 | fat quarter |
| Purple Butterfly Print #1816-02 | fat quarter |
| Blue Bird Print #1814-02 | fat quarter |
| Blue Egg Print #1818-02 | fat quarter |
| Blue Birdhouse Print #1817-01 | fat quarter |
| Purple Tonal #1819-02 | fat quarter |
| Yellow Tonal #1819-01 | fat quarter |
| Fuchsia Tonal #1819-04 | fat quarter |
| Pink Tonal #1819-03 | fat quarter |
| Green Tonal #4758-118 | 1 5/8 yards |
| Lt. Green Tonal #4758-83 | 3/4 yard |
| Backing: | 4 yards |
| Batting: | 70" x 70" |

Notions: thread for piecing, appliqué and quilting. accuquilt® GO! Leaves and Stems (#55331) and GO! Fun Flower (#55334). Fusible web if doing fusible appliqué. Templates are also provided in pattern.

Batting used is Warm & Natural® by The Warm Company

Designed by Christine Stainbrook

The information in this pattern is presented in good faith. Every effort has been taken to assure the accuracy herein.

This pattern may not be reproduced in any form, either electronic or hard copy. The finished product may not be used for mass retail, commercial, or wholesale purposes, markets, or trade shows without written permission.

© 2013 Project House 360

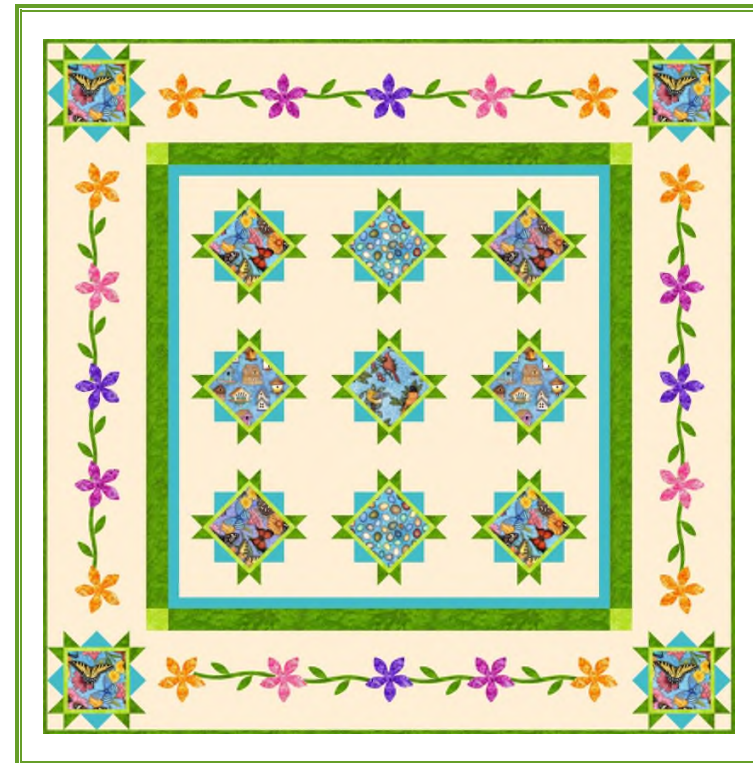

A Project House 360 Quilt Pattern
featuring fabric collections from



SPRING BLING

Color Card



Blue Bird Print
#1814-02



Pink Tonal
#1819-03



Blue Butterfly Print
#1816-01



Fuchsia Tonal
#1819-04



Purple Butterfly Print
#1816-02



Lt. Green Tonal
#4758-83



Blue Birdhouse Print
#1817-01



Green Tonal
#4758-118

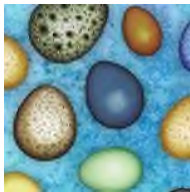

Blue Egg Print
#1818-02



Turquoise Solid
#9617-292



Yellow Tonal
#1819-01

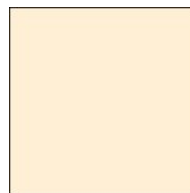

Cream Solid
#9617-67



Purple Tonal
#1819-02

SPRING BLING

Cutting:

Note: 5 3/4" square are fussy cut on the diagonal.

Cream Solid:

- 156 – 2" squares
- 52 – 2 3/8" squares
- 6 – 9 1/2" x 44"
- 4 – 9 1/2" squares
- 4 – 9 7/8" squares
- 2 – 6 3/8" squares

Yellow Tonal:

- 8 – GO! Fun Flowers

Lt. Green Tonal:

- 26 – 7/8" x 5 3/4"
- 26 – 7/8" x 6 1/2"
- 4 – 2 1/2" squares

Blue Butterfly Print:

- 6 – 5 3/4" squares

Purple Butterfly Print:

- 2 – 5 3/4" squares

Blue Egg Print:

- 2 – 5 3/4" squares

Fuchsia Tonal:

- 4 – GO! Fun Flowers

Pink Tonal:

- 4 – GO! Fun Flowers

Blue Birdhouse Print:

- 2 – 5 3/4" squares

Blue Bird Print:

- 1 – 5 3/4" square

Purple Tonal:

- 4 – GO! Fun Flowers

Turquoise Solid:

- 52 – 2" x 3 1/2"

- 4 – 1 1/2" x 44"

Green Tonal:

- 52 – 2 3/8" squares

- 4 – 2 1/2" x 40 1/4"

- 16 – GO! Stems *

- 32 – GO! Leaves *

*GO! Stems and Leaves used are the ones indicated below. Follow manufacturer's instructions to make appliqués fusible. If using templates, prepare appliqués using your favorite method.

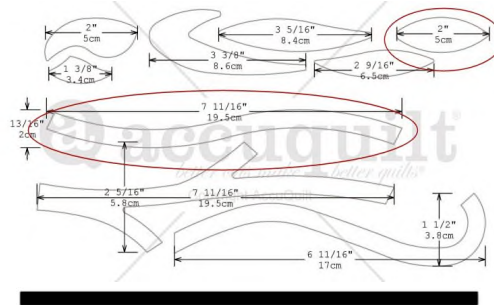

Blocks:

Make: 6 blue butterfly; 2 blue egg; 2 blue birdhouse; 2 purple butterfly and 1 blue bird print.

Add the lt. green tonal 7/8" x 5 3/4" strips to the sides of the 5 3/4" squares. Add the lt. green tonal 7/8" x 6 1/2" strips to the top and bottom of the squares.

Draw a diagonal line on 52 cream solid 2" squares. Add to the turquoise solid 2" x 3 1/2" rectangles. Stitch on the drawn line, then cut away the excess leaving a 1/4" seam allowance.

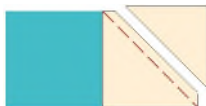

Press cream triangle outward. Repeat on other end of turquoise solid piece. Trim geese unit to 2" x 3 1/2" if necessary. Make 52 units.

Draw a diagonal line on the cream solid 2 3/8" squares. Add to the green tonal 2 3/8" squares,

stitching a 1/4" seam on each side of the drawn line. Cut on the drawn line and press toward the green fabric. Trim to 2" square if necessary. Make 104 units.

Combine the units with the remaining cream solid 2" squares to complete the block. Trim to 9 1/2" square if necessary.



Cut the cream solid 9 7/8" and 6 3/8" squares once diagonally. Set the blocks together using these triangles as well as the cream solid 9 1/2" squares and all blocks, putting four blue butterfly blocks aside. Stitch together as shown.

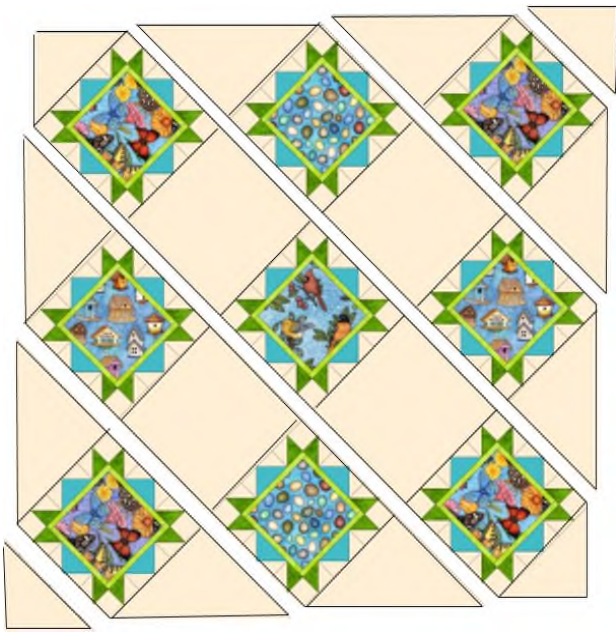

Add the turquoise solid 1 1/2" x 44" strips to the quilt, mitering corners.

Add the green tonal 2 1/2" x 40 1/2" strips to the sides of the quilt. Stitch a lt. green tonal 2 1/2" square to each end of the remaining green tonal 2 1/2" x 40 1/2" strips and add to the top and bottom of the quilt.



Cut two cream solid 9 1/2" x 44" strips in half. Add a whole strip to each piece. Cut to 9 1/2" x 44 1/4". Combine with the remaining blue butterfly blocks and add to the quilt.

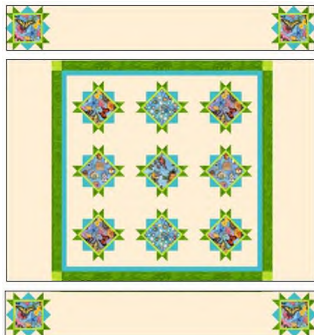

Appliqué:

Arrange appliqués as shown. Stitch in place.



Layer, baste and quilt as desired.

Bind with the remaining green tonal fabric.

FULL SIZE TEMPLATES – NO SEAM ALLOWANCE INCLUDED

